

DATA SHEET 12528.115.19900

## Folacoat Pearl

Inline finishing is becoming increasingly important, as indicated by the trend towards print products of ever-higher quality. Realising this, the Folex company now offers its customers the white Folacoat Pearl coating plate - a premium product for matt coating in offset printing.

The product is particularly attractive for companies in the commercial and packaging printing segment, who impose high demands on their products.

Folacoat Pearl can be used with both waterbased and UV varnish to achieve excellent matt coatings.

The coating plate can be quickly and easily stripped and ensures a long service life.

Please click [here](#) to find useful handling recommendation and interesting product introduction by video.

### Formats

Art.Number	Nominal thickness (inch)	Nominal thickness (mm)
12528.115.99900	.045	1.15
12528.135.99900	.053	1.35

### Rolls

Art.Number	Width (mm)	Length (mm)	Nominal thickness (inch)	Nominal thickness (mm)
12528.115.19900	1080	20	.045	1.15
12528.115.19900	1280	20	.045	1.15
12528.135.19900	1080	20	.053	1.35
12528.135.19900	1280	20	.053	1.35

## Technical data

### Characteristic



- Suitable for aqueous coating
- Suitable for UV coating
- Very good register stability even with long runs

### Specifications

Thickness of polymer layer	0.80 mm (.0315")
Thickness of carrier	0.35 mm (.0138")
Tolerance of thickness	± 0.05 mm (.002")
Type of coating transfer	direct coating
Plate hardness	83 Shore A
Nominal thickness (inch)	.045
Nominal thickness (mm)	1.15
Hardness of polymer (DIN 53505)	73 Shore A
Base Material	Polyester

### Handling

Recommended cutting depth: about 0.82 mm (.0322"). Please take care when cutting: The aim is to cleanly cut through the polymer and lightly score the base polyester, this will ensure clean removal of the polymer. The deeper the cut goes into the base material will have an influence on the life of the product. Too deep will shorten the life. Please ensure that the cutting depth is always constant. Avoid pulling at large areas that are not cut cleanly when removing as this will lift the areas that need to remain.

### Product liability clause

The foregoing information and any consulting provided by us in terms of application engineering shall be given to our best knowledge, but shall not be considered binding information neither with regard to any third party industrial property rights. Any such consulting shall not relieve you from your own review of our current consulting information as to their suitability for the intended procedures and applications. It is the users responsibility to determine the suitability for his/her own use and application and test through the complete production process to ensure the product is fully suitable for the intended use, since conditions of use are beyond our control. The sale of our products shall be subject to our current General Terms and Conditions. We reserve the right to make changes that serve to improve the product.



### FOLACOAT PEARL 1.15 (.045")

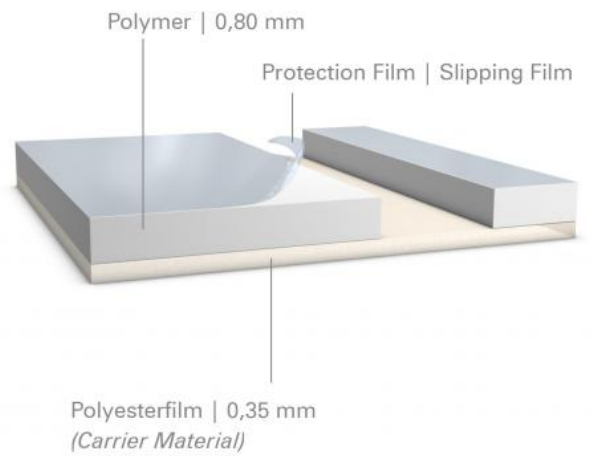

### FOLACOAT PEARL 1.35 (.053")

